

注：从右边起第一个位为前边脚

REVISION RECORD				
REV	ECO	DESCRIPTION	DRFT	DATE
△		整理图面	ZYH	12/26/08

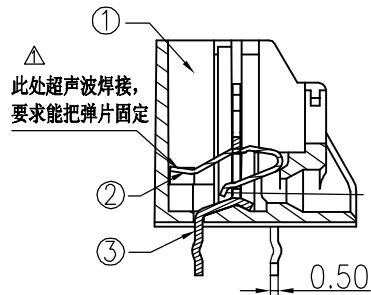

SECTION A-A

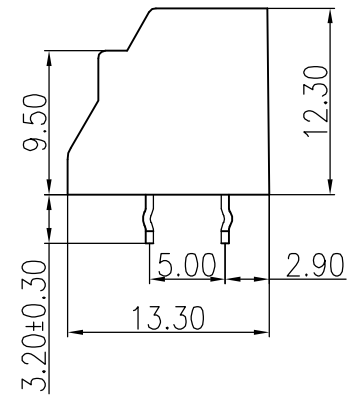
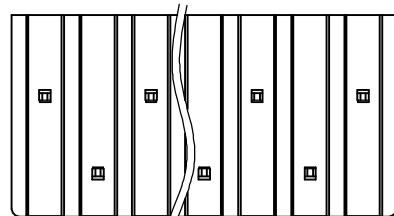
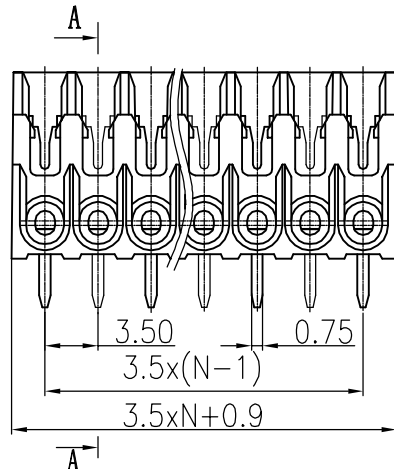
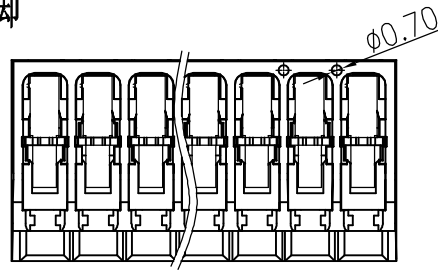

Notes:

1. Pitch: 3.5mm , Poles: 2-10P
2. Rated current: 4A
3. Rated voltage: 300V
4. Operation temperatures: -40°C ~ +105°C
5. Withstanding Voltage: AC1500V/1Min
6. Insulation Resistance: 5000MΩ / DC1000V
7. Wire Range: 20~18AWG
8. Undimensioned Tolerances:

Pitch range in mm		Nominal dimension range in mm						
to 6	over 6 to 10	over 10 to 24	to 6	over 6 to 30	over 30 to 90	over 90 to 200	to 200 to 480	— ∩ ∇
±0.10	±0.15	±0.25	±0.1	±0.2	±0.3	±0.5	±0.7	0.05/10

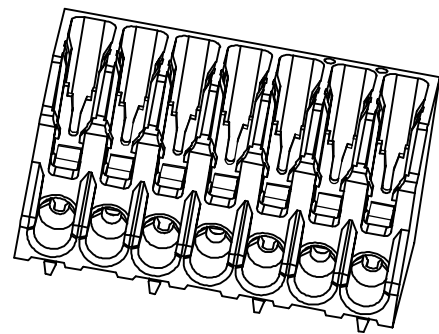

3	DG251A-3.5-Spring	X000001240	XX	Stainless steel	
2	DG251A-3.5-Pin header	3029B00010	XX	Phosphor bronze	SnCe Plated
1	DG251A-3.5-Housing(00A)	3029A0YXXA	1	PA66	UL94V-0
ITEM	NAME OF PART	NO. OF PART	Q'TY	MATERIAL	NOTES
DETACHED LISTS	MM (INCH)	DFTO ZYH	DATE 09/21/07	宁波高正电子有限公司 DEGSON ELECTRONICS CO., LTD NAME DG251A-3.5-XXP-1Y-00A(H) DRAWING NO. DG251A-3.5-E01 /PART NO. SIZE A4 REV T1 12/26/08	
	TOLERANCES EXCEPT AS NOTED		CHKD DATE		
	MM	±	APPVL DATE		
	.0 ±	±	MATERIAL :		
.00 ±	±	G.E. :	DRAWING NO. DG251A-3.5-E01		
.000 ±	±	FINISH :	/PART NO.		
ANGLES ± 1°	THIRD ANGLE PROJECTION		SCALE : 1:1	DO NOT SCALE DRAWING	SHEET 1 OF 1