

REVISION RECORD				
REV	ECO	DESCRIPTION	DRFT	DATE
△		Drawing Revise	WF	11/11/06*
△		PC10端子线改为PC10-PE端子线 料号由X000001290改为X000001290	WF	11/23/06*
△		品名、料号增加环保标示“(H)”	LJH	12/10/07*
△		增加VDE刻字及参数	Zengy	08/23/08*

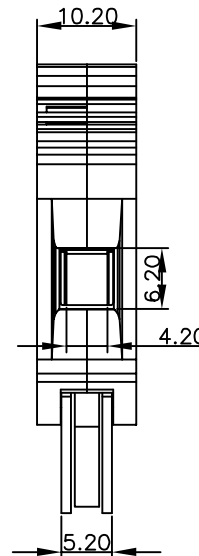
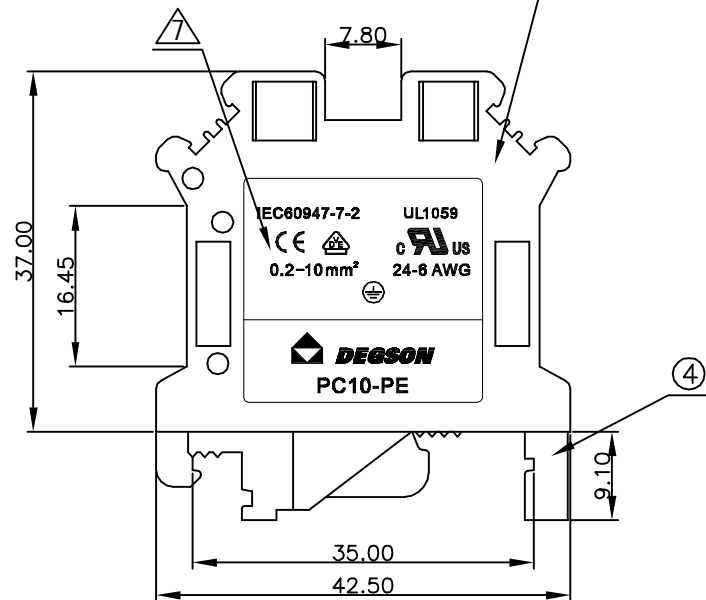
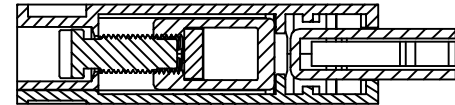
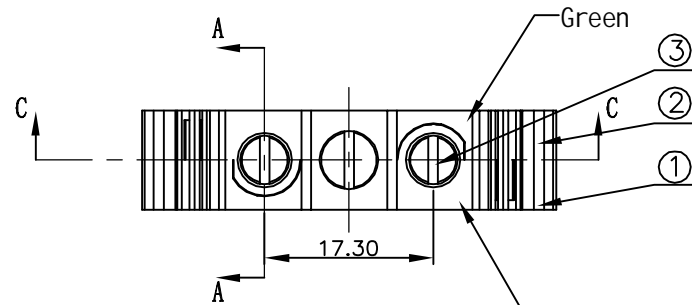

Notes:

1. Thickness: 10.2mm
2. Operation temperatures: -40°C ~ +105°C
3. Wire Range: 24~6AWG, 0.2~10mm²
4. Max. Torque Value: M4, 12.24kgf.cm
5. Undimensioned Tolerances:

Pitch range in mm		Nominal dimension range in mm					—	
	over 6	over 10		over 30	over 60	over 100	over 150	⌒
to 6	to 10	to 24	to 30	to 60	to 100	to 150		▭
±0.10	±0.15	±0.25	±0.2	±0.3	±0.5	±0.7	±1.0	0.05/10

3	PC6-SCREW	S000001490 (H)	2	Brass	Ni plated
2	PC10-PE-HOUSING	6008A0401A (H)	1	PA66	UL94V-0
1	PC10-PE-HOUSING	6008A0801A (H)	1	PA66	UL94V-0
ITEM	NAME OF PART	NO. OF PART	Q'TY	MATERIAL	NOTES
DETACHED LISTS	MM (INCH)	DFTO longle	DATE 01/10/05	宁波高正电子有限公司 DEGSON ELECTRONICS CO., LTD NAME PC10-PE-01P-1Y-00A(H) DRAWING NO. PC10-PE-E01 SIZE REV /PART NO. A3 17 08/23/08*	
	TOLERANCES EXCEPT AS NOTED		CHKD DATE		
	MM	±	MFO DATE		
	.0 ±	±	APPVL DATE		
	.000 ±	±	MATERIAL :		
ANGLES ± 1°	G.E :		DO NOT SCALE DRAWING SHEET 1 OF 1		
THIRD ANGLE PROJECTION	FINISH :		SCALE : 1:1		

△	5	PC10-PE-BRASS CAGE	X000001290 (H)	2	Brass	Ni plated
	4	PC10-PE-GROUNDING PART	6008B00010 (H)	1	Steel	Zn plated