

Features

- $V_{DS} = -20\text{ V}$, $I_D = -0.66\text{ A}$
 $R_{DS(on)} < 0.52\Omega$ @ $V_{GS} = -4.5\text{ V}$
 $R_{DS(on)} < 0.78\Omega$ @ $V_{GS} = -2.5\text{ V}$
- Enables High Density PCB Manufacturing
- Low Voltage Drive Makes this Device Ideal for Portable Equipment
- Advanced Trench Process Technology
- ESD protected

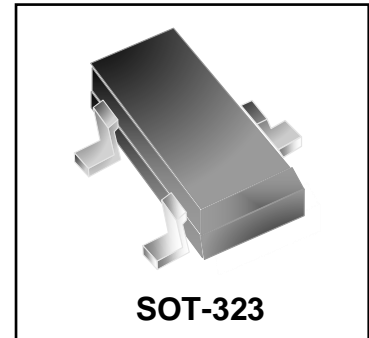

Mechanical Characteristics

- SOT-323 Package
- Marking : Making Code
- RoHS Compliant

Schematic & PIN Configuration

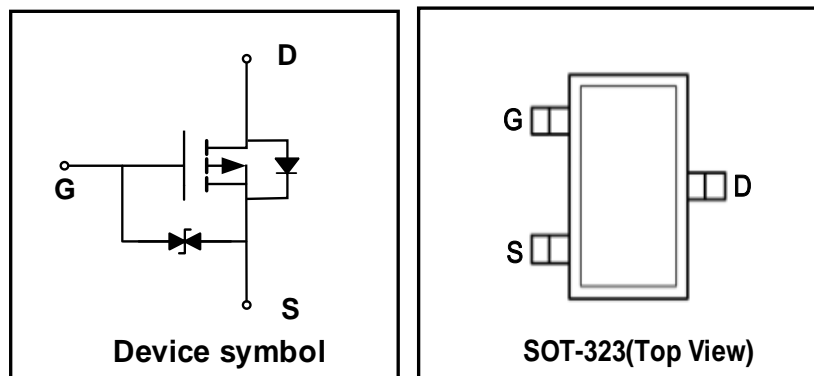

Absolute Maximum Rating

Parameter	Symbol	Value	Unit
Drain-Source Voltage	V_{DS}	-20	V
Gate-Source Voltage	V_{GS}	± 12	V
Continuous Drain Current	I_D	-0.66	A
Pulsed Drain Current	I_{DM}	-2.64	A
Power Dissipation	P_D	200	mW
Junction Temperature	T_J	150	$^{\circ}\text{C}$
Storage Temperature	T_{STG}	-55 to +150	$^{\circ}\text{C}$
Thermal Resistance from Junction to Ambient	$R_{\theta JA}$	625	$^{\circ}\text{C/W}$

Electrical Characteristics (T_{amb}=25°C unless otherwise noted)

Parameter	Symbol	Test Condition	Min.	Typ.	Max.	Unit
Static Characteristics						
Drain-Source Breakdown Voltage	BV_{DSS}	V _{GS} = 0 V, I _D = -250μA	-20	-	-	V
Zero Gate Voltage Drain Current	I_{DSS}	V _{DS} = -20V, V _{GS} = 0 V	-	-	-1	μA
Gate-body Leakage Current	I_{GSS}	V _{DS} = 0 V, V _{GS} = ±10V	-	-	±20	μA
Drain-Source On-state Resistance ¹	R_{DS(on)}	V _{GS} = -4.5V, I _D = -0.66A	-	450	520	mΩ
		V _{GS} = -2.5V, I _D = -0.60A	-	650	780	
		V _{GS} = -1.8V, I _D = -0.50A	-	950	-	
Gate Threshold Voltage	V_{GS(th)}	V _{DS} = V _{GS} , I _D = -250μA	-0.3	-0.6	-1.1	V
Forward transconductance ¹	g_{fs}	V _{DS} = -10V, I _D = -0.54A	-	0.8	-	S
Dynamic Characteristics						
Input Capacitance	C_{iss}	V _{GS} = 0V, V _{DS} = -16V, f = 1MHz	-	113	-	pF
Output Capacitance	C_{oss}		-	15	-	
Reverse Transfer Capacitance	C_{rss}		-	9	-	
Switching Characteristics						
Turn-On Delay Time ²	t_{d(on)}	V _{DS} = -10V, V _{GS} = -4.5V, I _D = -0.2A, R _G =10Ω	-	9	-	ns
Turn-On Rise Time ²	t_r		-	5.7	-	
Turn-Off Delay Time ²	t_{d(off)}		-	32.6	-	
Turn- Off Fall Time ²	t_f		-	20.3	-	
Source-Drain Diode Characteristics						
Body Diode Voltage	V_{DS}	I _S = -0.5A, V _{GS} = 0V	-	-	-1.2	V

Notes :

1.Pulse Test: Pulse Width < 300μs, Duty Cycle ≤2%.

2.Guaranteed by design, not subject to production testing

Typical Characteristics

Figure 1. Output Characteristics

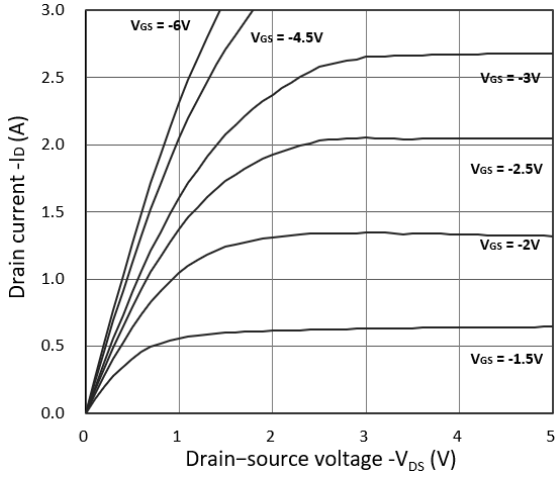

Figure 3. $R_{DS(ON)}$ vs. I_D

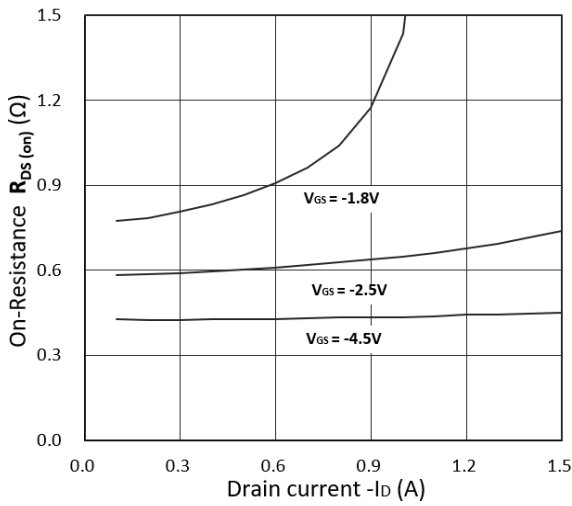

Figure 5. I_S vs. V_{SD}

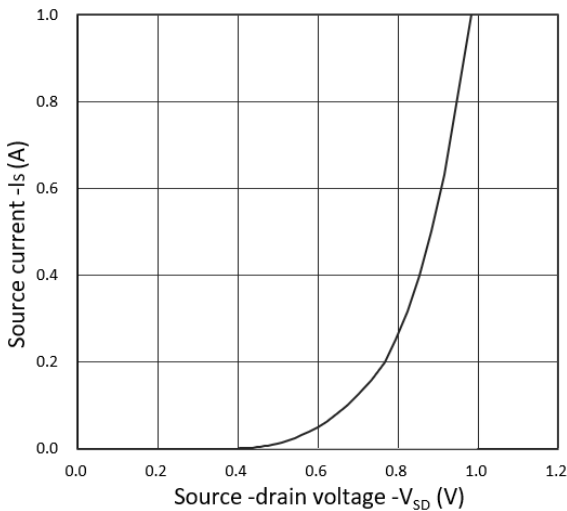

Figure 2. Transfer Characteristics

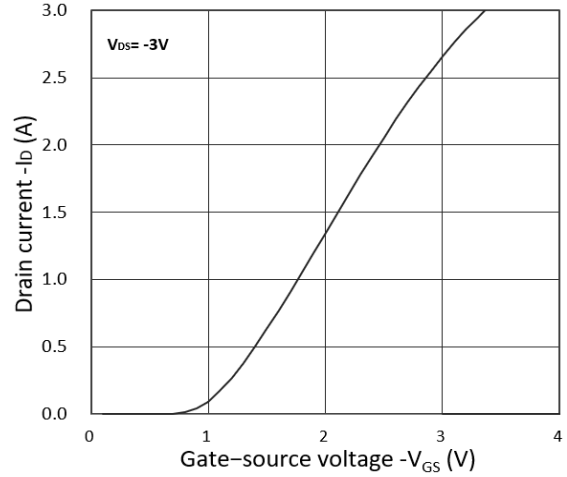

Figure 4. $R_{DS(ON)}$ vs. V_{GS}

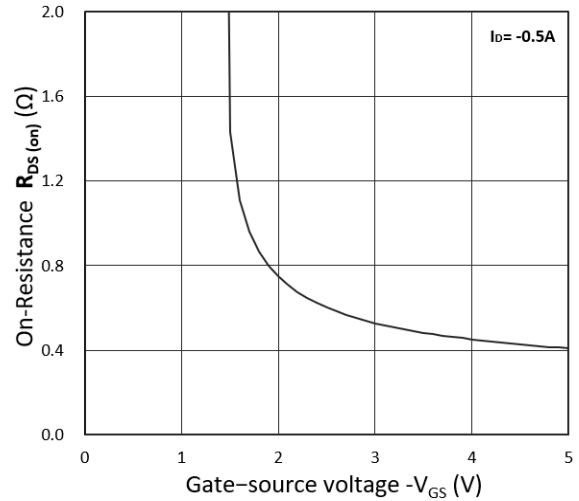
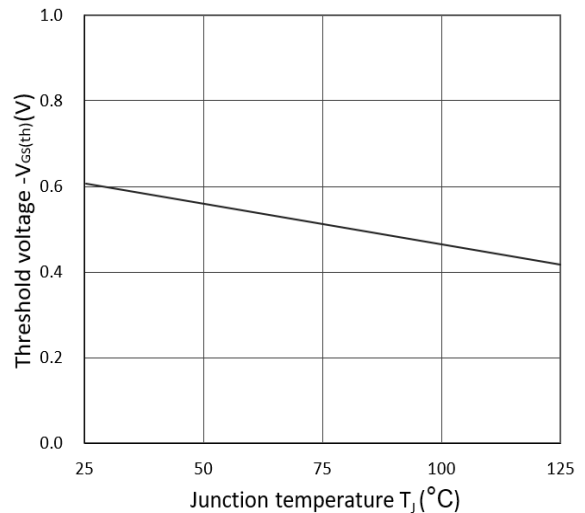

Figure 6. Threshold Voltage



Outline Drawing – SOT-323

PACKAGE OUTLINE

SOT-323

SYMBOL	MILLIMETER		INCHES	
	MIN.	MAX.	MIN.	MAX.
A	0.900	1.100	0.035	0.043
A1	0.000	0.100	0.000	0.004
A2	0.900	1.000	0.035	0.039
D	2.000	2.200	0.079	0.087
b	0.200	0.400	0.008	0.016
c	0.080	0.150	0.003	0.006
E	2.150	2.450	0.085	0.096
E1	1.150	1.350	0.045	0.053
e	0.650TYP		0.026TYP	
L	0.525 REF		0.021 REF	
θ	0	8°	0	8°

DIMENSIONS		
DIM	INCHES	MILLIMETERS
M	0.076	1.90
C	0.036	0.9
Z	0.108	2.7
e	0.026	0.65
e1	0.052	1.30
b	0.028	0.7

Notes

1. Dimensioning and tolerances per ANSI Y14.5M, 1985.
2. Controlling Dimension: Inches
3. Pin 3 is the cathode (Unidirectional Only).
4. Dimensions are exclusive of mold flash and metal burrs.

Marking Codes

Part Number	WM02P06G
Marking Code	

Package Information

Qty: 3k/Reel

CONTACT INFORMATION

No.1001, Shiwan (7) Road, Pudong District, Shanghai, P.R.China.201207

Tel: 86-21-68969993 Fax: 86-21-50757680 Email: market@way-on.com

WAYON website: <http://www.way-on.com>

For additional information, please contact your local Sales Representative.

WAYON ® is registered trademark of Wayon Corporation.

*Specifications are subject to change without notice.
The device characteristics and parameters in this data sheet can and do vary in different applications and actual device performance may vary over time.
Users should verify actual device performance in their specific applications.*