

700V Silicon N-channel Power MOSFET

Description

WMOSTM DM, the silicon N-channel enhanced VDMOSFETs, is obtained by the self-aligned planar technology which reduce the conduction loss, improve switching performance and enhance the avalanche energy. The transistor can be used in various power switching circuit for system miniaturization and higher efficiency.

Features

- Fast switching
- Typ. $R_{DS(on)} = 0.95\Omega$
- Low gate charge (Typ. $Q_g = 26.11nC$)
- Typ. $C_{rss} = 4.4pF$
- 100% UIS tested

Applications

LED Lighting, Charger, Adapter, PC, LCD TV, Server

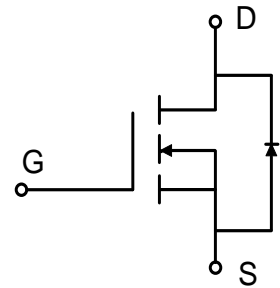
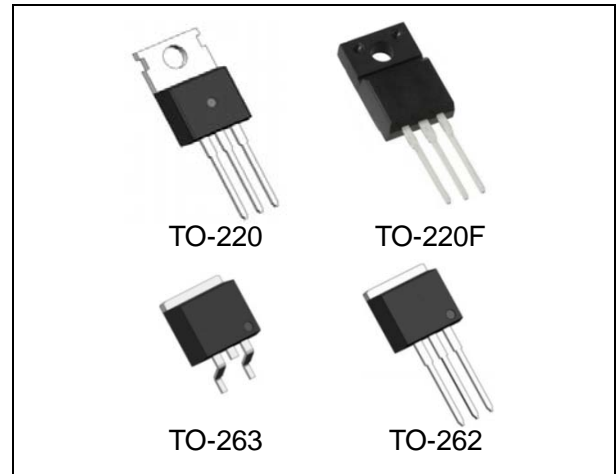

Absolute Maximum Ratings

Parameter	Symbol	WML	WMK/M/N	Unit
Drain-source voltage	V_{DSS}	700		V
Continuous drain current ($T_C = 25^\circ C$) ($T_C = 100^\circ C$)	I_D	8		A
		5.1		A
Pulsed drain current ¹⁾	I_{DM}	32		A
Gate-source voltage	V_{GS}	± 30		V
Avalanche energy, single pulse ²⁾	E_{AS}	504		mJ
Power dissipation ($T_C = 25^\circ C$) - Derate above $25^\circ C$	P_D	52	140	W
		0.42	1.12	W/ $^\circ C$
Operating and storage temperature range	T_J, T_{STG}	-55 to +150		$^\circ C$
Continuous diode forward current	I_S	7		A
Diode pulse current	$I_{S,pulse}$	28		A

Thermal Characteristics

Parameter	Symbol	WML	WMK/M/N	Unit
Thermal resistance, junction-to-case	$R_{\theta JC}$	2.40	0.89	$^\circ C/W$
Thermal resistance, junction-to-ambient	$R_{\theta JA}$	62.5	62.5	$^\circ C/W$

Electrical Characteristics $T_c = 25^\circ\text{C}$, unless otherwise noted

Parameter	Symbol	Test Condition	Min.	Typ.	Max.	Unit
Static characteristics						
Drain-source breakdown voltage	BV_{DSS}	$V_{GS}=0\text{ V}, I_D=0.25\text{ mA}$	700	-	-	V
Gate threshold voltage	$V_{GS(th)}^{3)}$	$V_{DS}=V_{GS}, I_D=0.25\text{ mA}$	2	-	4	V
Drain cut-off current	I_{DSS}	$V_{DS}=700\text{ V}, V_{GS}=0\text{ V}$	-	-	1	μA
Gate leakage current, forward	I_{GSSF}	$V_{GS}=30\text{ V}, V_{DS}=0\text{ V}$	-	-	100	nA
Gate leakage current, reverse	I_{GSSR}	$V_{GS}=-30\text{ V}, V_{DS}=0\text{ V}$	-	-	-100	nA
Drain-source on-state resistance	$R_{DS(on)}^{3)}$	$V_{GS}=10\text{ V}, I_D=4\text{ A}$	-	0.95	1.2	Ω
Dynamic characteristics						
Input capacitance	C_{iss}	$V_{DS}=25\text{ V}, V_{GS}=0\text{ V},$ $f=1\text{ MHz}$	-	1357	-	pF
Output capacitance	C_{oss}		-	124.2	-	
Reverse transfer capacitance	C_{rss}		-	4.4	-	
Turn-on delay time	$t_{d(on)}$	$V_{DD}=350\text{ V}, I_D=8\text{ A}$ $R_G=25\Omega, V_{GS}=10\text{ V}$	-	26.48	-	ns
Rise time	t_r		-	39.96	-	
Turn-off delay time	$t_{d(off)}$		-	86.80	-	
Fall time	t_f		-	43.36	-	
Gate charge characteristics						
Gate to source charge	Q_{gs}	$V_{DD}=560\text{ V}, I_D=8\text{ A},$ $V_{GS}=0\text{ to }10\text{ V}$	-	7.47	-	nC
Gate to drain charge	Q_{gd}		-	8.51	-	
Gate charge total	Q_g		-	26.11	-	
Reverse diode characteristics						
Diode forward voltage	V_{SD}	$V_{GS}=0\text{ V}, I_F=8\text{ A}$	-	-	1.4	V
Reverse recovery time	t_{rr}	$I_F=8\text{ A}, dI_F/dt=100\text{ A}/\mu\text{s}$	-	515	-	ns
Reverse recovery charge	Q_{rr}	$V_{GS}=0\text{ V}$	-	4.22	-	μC

Notes:

1. Repetitive rating: pulse width limited by maximum junction temperature
2. $I_{AS}=5.8\text{ A}, V_{DD}=50\text{ V}, R_G=25\Omega$, starting $T_J = 25^\circ\text{C}$
3. Pulse test: pulse width $\leq 300\mu\text{s}$, duty cycle $\leq 2\%$.

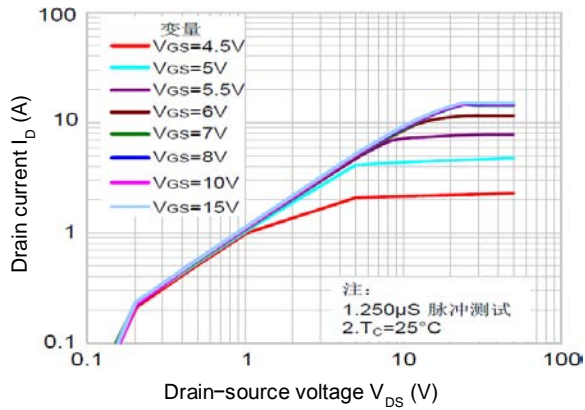

Figure 1. On-Region Characteristics

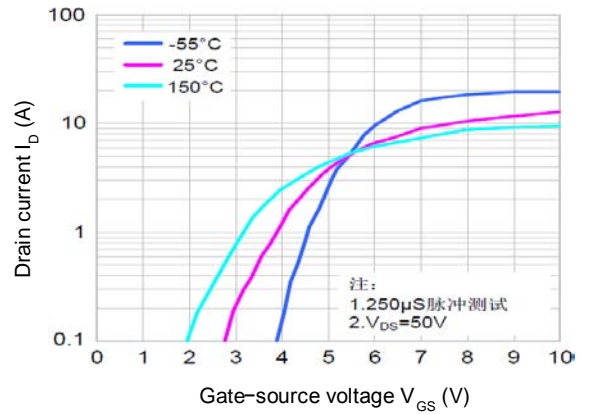

Figure 2. Transfer Characteristics

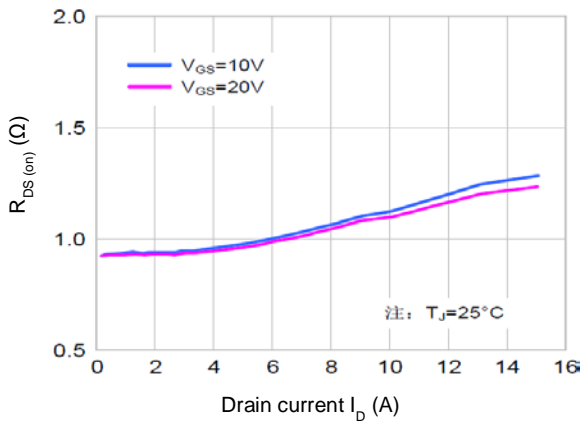

Figure 3. On-Resistance Variation vs. Drain Current

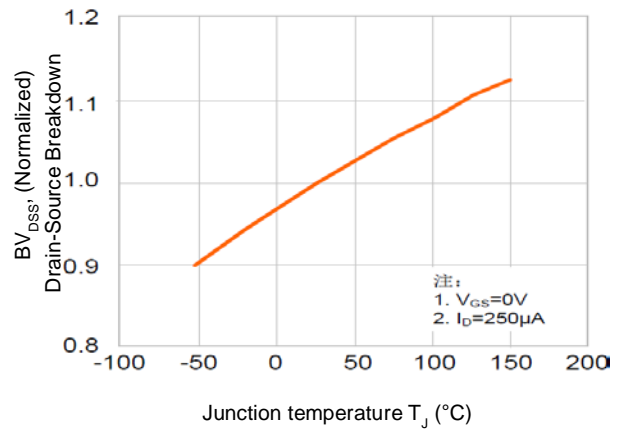

Figure 4. Breakdown Voltage vs. Temperature

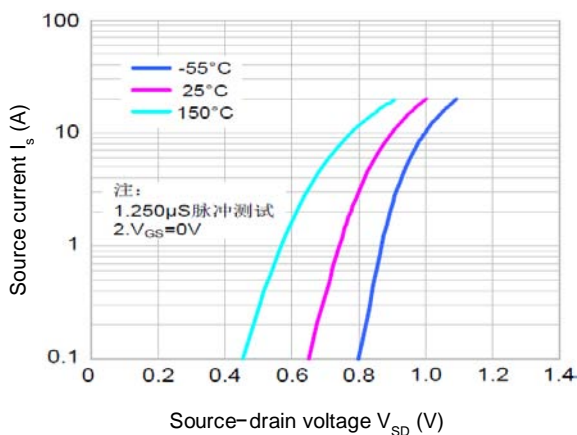

Figure 5. Source Current Variation vs. Source-drain Voltage

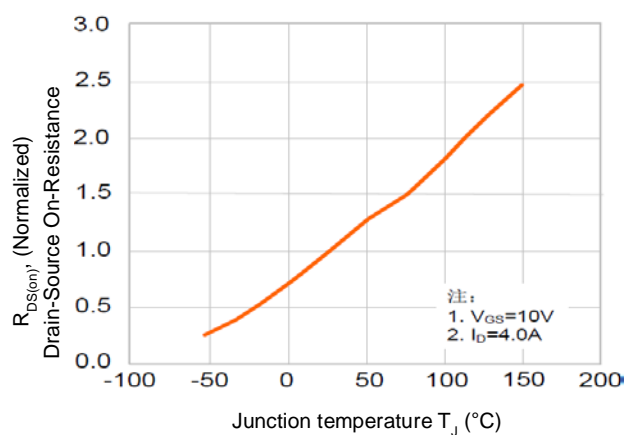

Figure 6. On-Resistance vs. Temperature

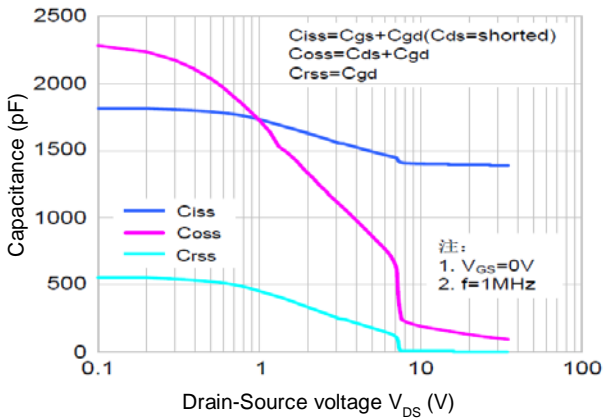

Figure 7. Capacitance Characteristics

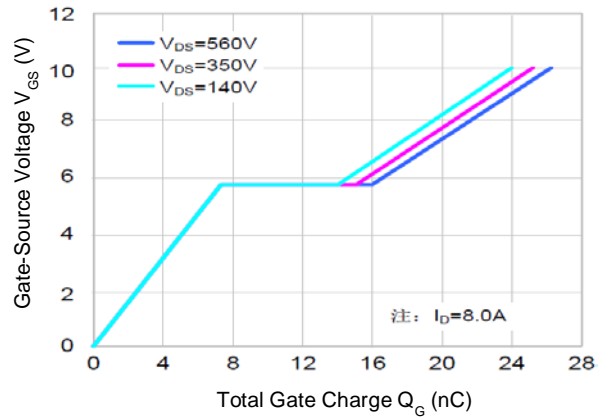

Figure 8. Gate Charge Characteristics

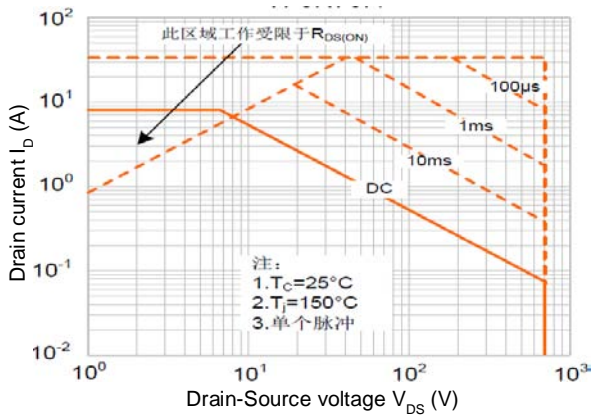

Figure 9. Maximum Safe Operating Area (WML07N65DM)

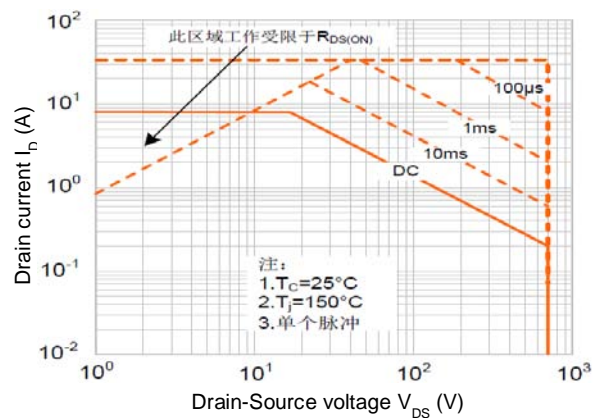

Figure 10. Maximum Safe Operating Area (WMK/M/N07N65DM)

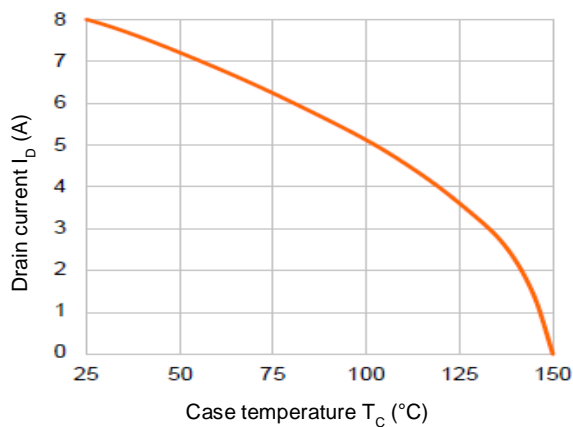
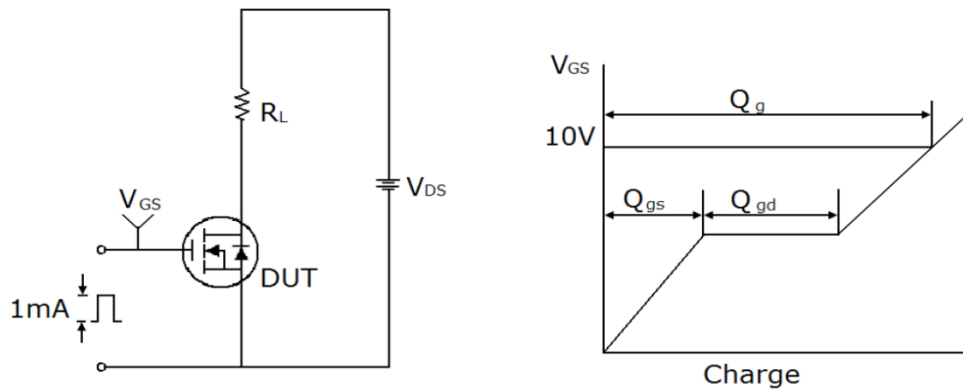
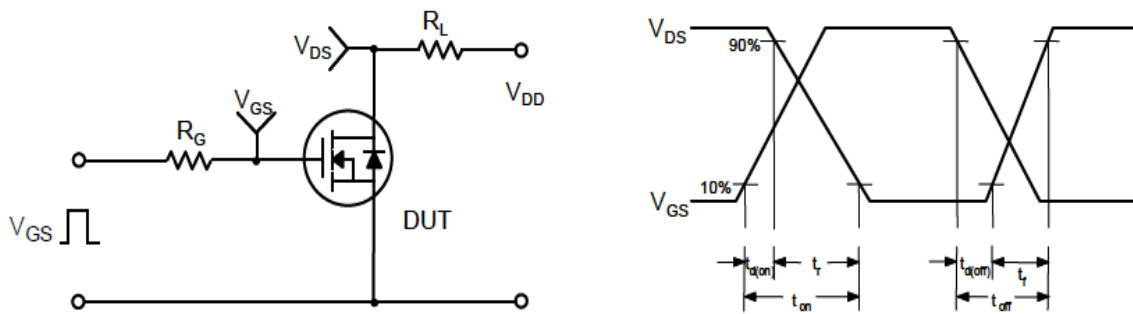

Figure 11. Drain Current vs. Case Temperature

Gate Charge Test Circuit & Waveform



Switching Test Circuit & Waveforms



Unclamped Inductive Switching Test Circuit & Waveforms

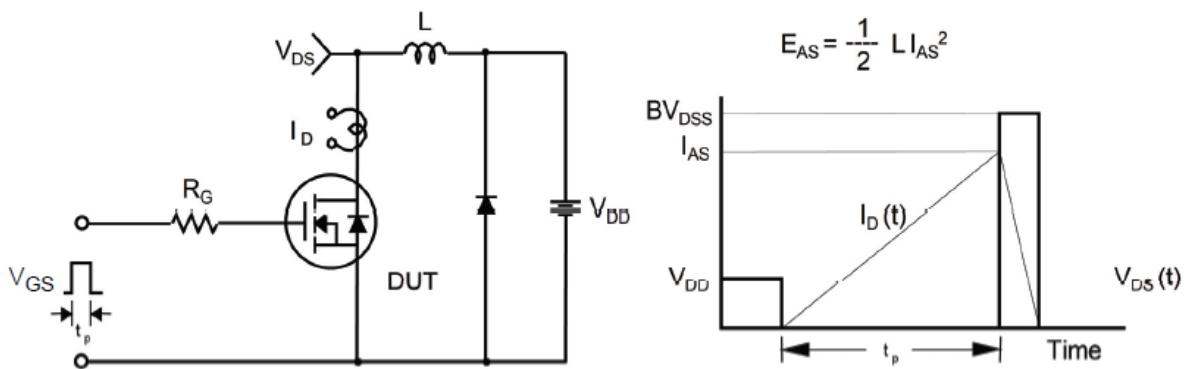

Mechanical Dimensions for TO-220

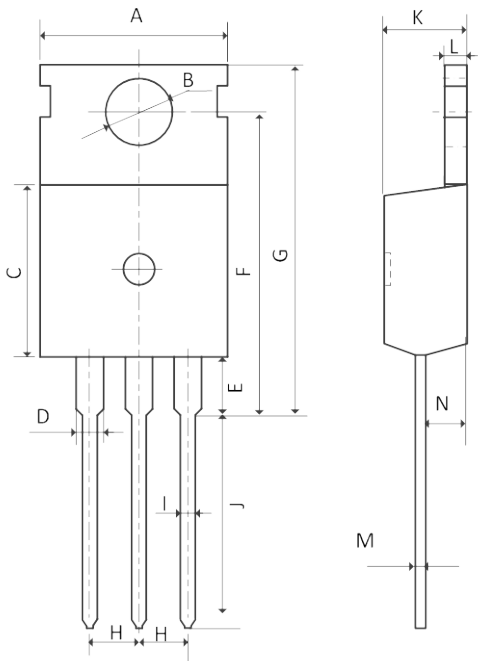

COMMON DIMENSIONS

SYMBOL	MM	
	MIN	MAX
A	9.70	10.10
B	3.50	3.70
C	9.00	9.40
D	1.17	1.47
E	2.80	3.20
F	15.80	16.20
G	18.95MAX	
H	2.44	2.64
I	0.70	0.90
J	9.78	10.38
K	4.30	4.70
L	1.20	1.40
M	0.40	0.60
N	2.25	2.55

Mechanical Dimensions for TO-220F

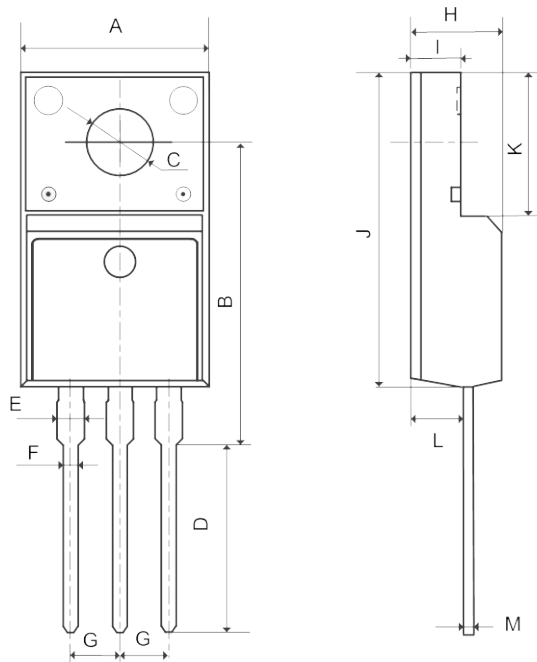

COMMON DIMENSIONS

SYMBOL	MM	
	MIN	MAX
A	9.96	10.36
B	15.50	16.10
C	3.08	3.28
D	12.64	13.24
E	1.18	1.58
F	0.70	0.90
G	2.39	2.69
H	4.50	4.90
I	2.34	2.74
J	15.67	16.07
K	6.50	6.90
L	2.56	2.96
M	0.40	0.60

Mechanical Dimensions for TO-263

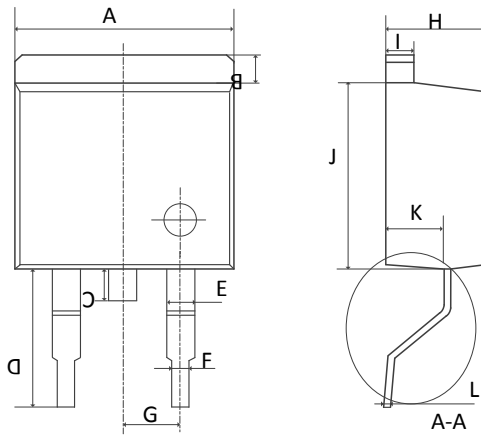

COMMON DIMENSIONS

SYMBOL	MM	
	MIN	MAX
A	10.00	10.40
B	1.11	1.41
C	1.25	1.55
D	5.10	5.50
E	1.12	1.42
F	0.71	0.91
G	2.39	2.69
H	4.49	4.89
I	1.17	1.37
J	8.45	8.85
K	2.54	2.84
L	0.28	0.48

Mechanical Dimensions for TO-262

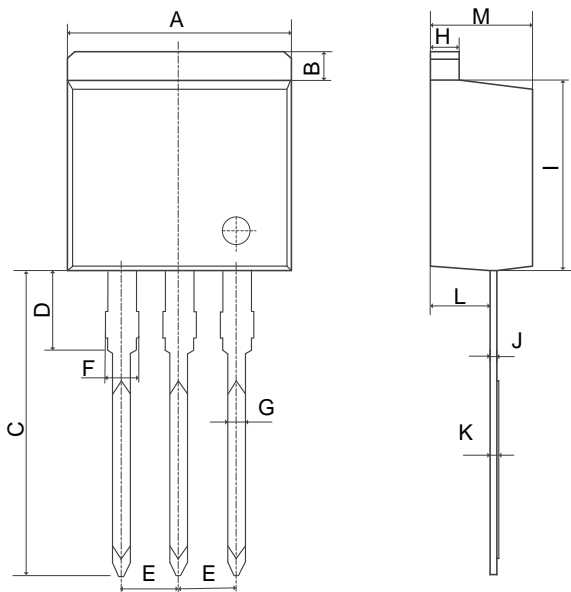

COMMON DIMENSIONS

SYMBOL	MM	
	MIN	MAX
A	10.00	10.40
B	1.11	1.41
C	13.56	14.16
D	3.58	3.98
E	2.39	2.69
F	1.07	1.47
G	0.71	0.91
H	1.17	1.37
I	8.45	8.85
J	0.28	0.48
K	0.32	0.52
L	2.54	2.84
M	4.50	4.90

Ordering Information

Part	Package	Marking	Packing method	Quantity
WMK08N70DM	TO-220	WMK08N70DM	Tube	50
WML08N70DM	TO-220F	WML08N70DM	Tube	50
WMM08N70DM	TO-263	WMM08N70DM	Tape and Reel	800
WMN08N70DM	TO-262	WMN08N70DM	Tube	50

Marking Information

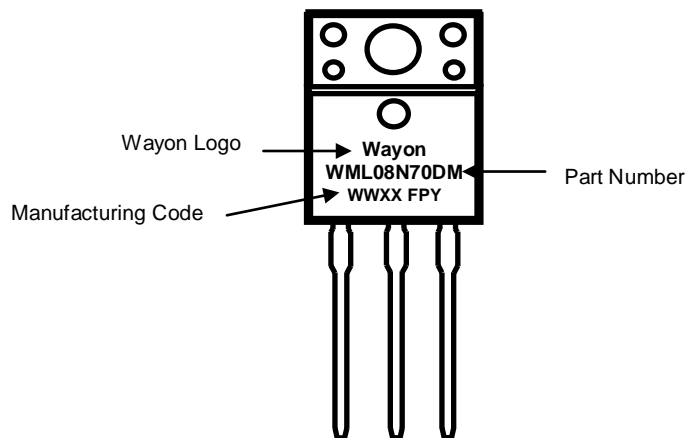

Contact Information

CYG WAYON CIRCUIT PROTECTION CO., LTD.

No.1001, Shiwan(7) Road, Pudong District, Shanghai, P.R.China.201202

Tel: 86-21-50310888 Fax: 86-21-50757680 Email: market@way-on.com

WAYON website: <http://www.way-on.com>

For additional information, please contact your local Sales Representative.

CYG WAYON ® is registered trademarks of Wayon Corporation.

Disclaimer

CYG WAYON reserves the right to make changes without further notice to any products herein to improve reliability, function, or design. The Products are not designed for use in hostile environments, including, without limitation, aircraft, nuclear power generation, medical appliances, and devices or systems in which malfunction of any Product can reasonably be expected to result in a personal injury. The information given in this document shall in no event be regarded as a guarantee of conditions or characteristics. CYG WAYON does not assume any liability for infringement of patents, copyrights, or other intellectual property rights of third parties by or arising from the use of Products or technical information described in this document.