

30V、200mA Low Power LDO

SSP7935

General Description

The SSP7935 series is a group of positive voltage output, three-pin regulators, that provide a high current even when the input/output voltage differential is small. Low power consumption and high accuracy is achieved through CMOS and laser trimming technologies.

The SSP7935 consists of a high-precision voltage reference, an error amplification circuit, and a current limited output driver. Transient response to load variations have improved in comparison to the existing series.

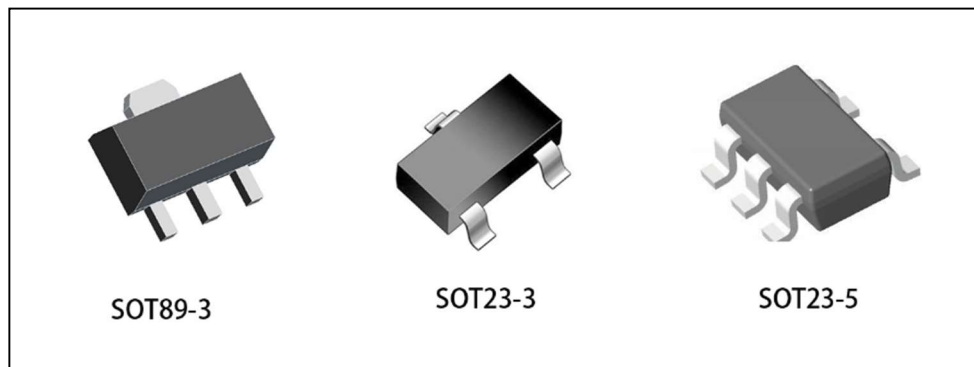

Features

- High input voltage: 30V
- Low temperature coefficient
- Integrated Short-Circuit Protection
- Large Output Current: 200mA
- Low Quiescent Current: 1.6 μ A
- Output voltage accuracy: tolerance $\pm 2\%$
- Built-in current limiter
- Packages: SOT89-3, SOT23-3 and SOT23-5

Applications

- Battery-powered equipment
- Smoke detector and sensor
- Home Appliance
- Microcontroller Applications

Order information

Product model	Package	Manner of packing	packing quantity
SSP7935PxxPR	SOT89-3	Reel	1000
SSP7935PxxMR	SOT23-3		3000
SSP7935PxxM5R	SOT23-5		3000

Selection Guide Table

SSP7935P① ② ③ ④

Designator	Symbol	Description
① ②	Integer	Output Voltage(2.5V~5.0V)
③	P	Package:SOT89-3
	M	Package:SOT23-3
	M5	Package:SOT23-5
④	R	RoHS / Pb Free
	G	Halogen Free

Note: "① ②" stands for output voltages. Other voltages can be specially customized.

Part No.	Output Voltage	Package
SSP7935P25XX	2.5V	SOT89-3 SOT23-3 SOT23-5
SSP7935P27XX	2.7V	
SSP7935P30XX	3.0V	
SSP7935P33XX	3.3V	
SSP7935P36XX	3.6V	
SSP7935P40XX	4.0V	
SSP7935P44XX	4.4V	
SSP7935P50XX	5.0V	

Functional Block Diagram

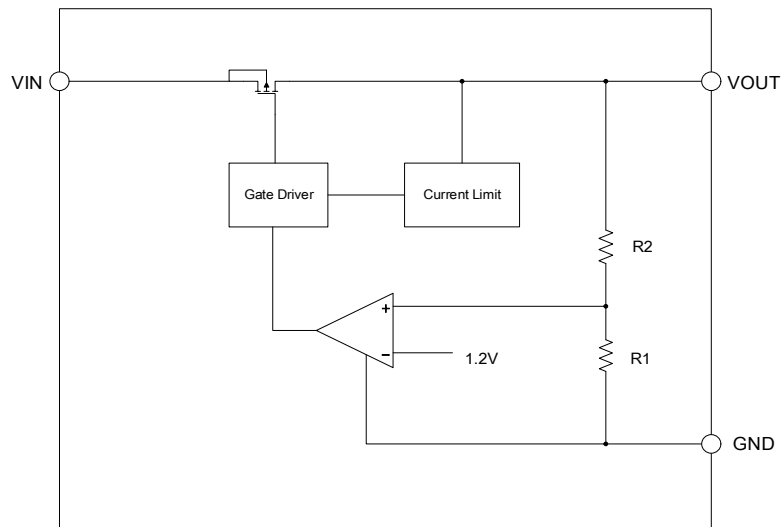

Pin Assignment

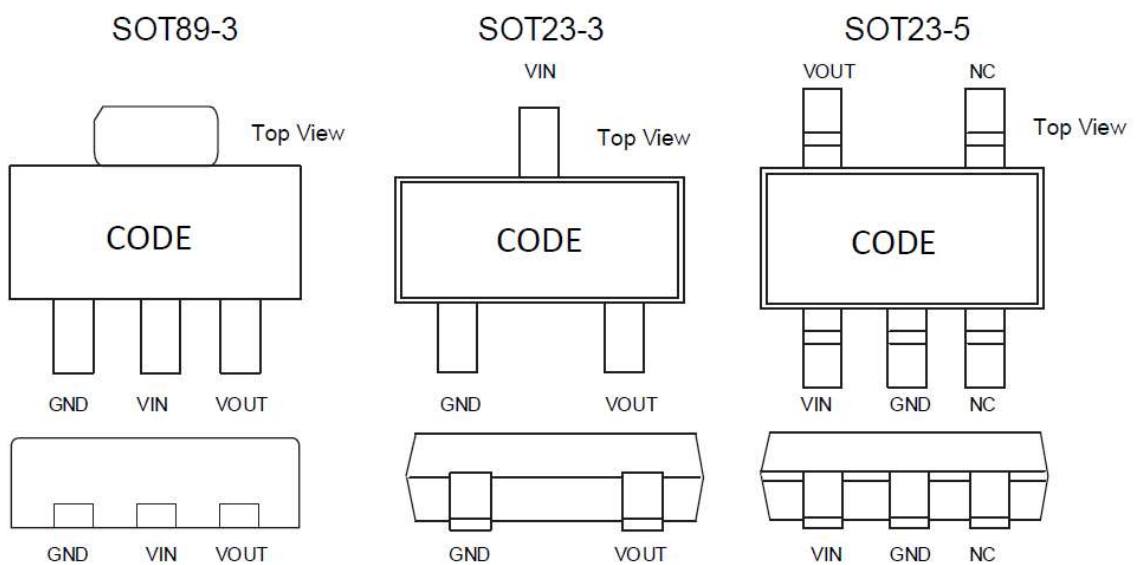

Absolute Maximum Ratings

Parameter	Description	Min	Max	Unit
Voltage	VIN Pin to GND Pin	-0.3	35	V
	VOOUT Pin to GND pin	-0.3	6	V
	VOOUT Pin to VIN Pin	-35	0.3	V
Current	Peak output	450mA		
Temperature	Operating Ambient Temperature	-40	85	°C
	Storage Temperature	-40	150	°C
	Operating virtual junction Temperature	-	150	°C
Thermal Resistance (Junction to Ambient)	SOT89-3	180		°C/W
	SOT23-3	380		°C/W
	SOT23-5	300		°C/W
Power Dissipation	SOT89-3	600		mW
	SOT23-3	300		mW
	SOT23-5	400		mW
Electrostatic discharge rating	Human Body Model (HBM)	4		kV
	Charged Device Model (MM)	100		V

Note: These are just the limit parameters. Beyond the range specified in the Absolute Maximum Ratings may cause serious damage to the equipment. Long exposure to extreme conditions may affect the reliability of the device.

Electrical Characteristics

(At TA=25°C, CIN=1uF, VIN=VOUTNOM+1.0V, COUT=10μF, unless otherwise noted)

Parameter	Symbol	Test Conditions	MIN	TYP	MAX	UNIT
Input Voltage	V _{IN}		—	—	35	V
Quiescent Current	I _{GND}	V _{IN} =12V, No load	—	1.6	—	μA
Output Voltage	V _{OUT}	V _{IN} =12V, I _{OUT} =10mA	V _{OUTNOM} *0.98	V _{OUTNOM}	V _{OUTNOM} *1.02	V
Output Current	I _{OUT_MAX}		200	250	—	mA
Dropout Voltage(1)	V _{DROP}	I _{OUT} =10mA , ΔV _{OUT} =-V _{OUTNOM} *2%	—	30	—	mV
		I _{OUT} =100mA , ΔV _{OUT} =- V _{OUTNOM} *2%	—	300	—	mV
		I _{OUT} =200mA , ΔV _{OUT} =- V _{OUTNOM} *2%	—	600	—	mV
Load Regulation	ΔV _{OUT}	1mA≤I _{OUT} ≤100mA	—	20	—	mV
Line Regulation	$\frac{\Delta V_{OUT}}{\Delta V_{IN} \times V_{OUT}}$	I _{OUT} =1mA, V _{IN} =(V _{OUTNOM} +1V) to 35V	—	0.2	—	%/V
Current Limit	I _{LIMIT}	V _{IN} =(V _{OUTNOM} +1V) to 35V R _{LOAD} =V _{OUTNOM} /1A	—	450	—	mA
Thermal Shutdown Temperature	T _{SHDN}		—	125	—	°C

Note:(1)Dropout Voltage is the voltage difference between the input and the output at which the output voltage drops 2% below its nominal value.

Application Circuits

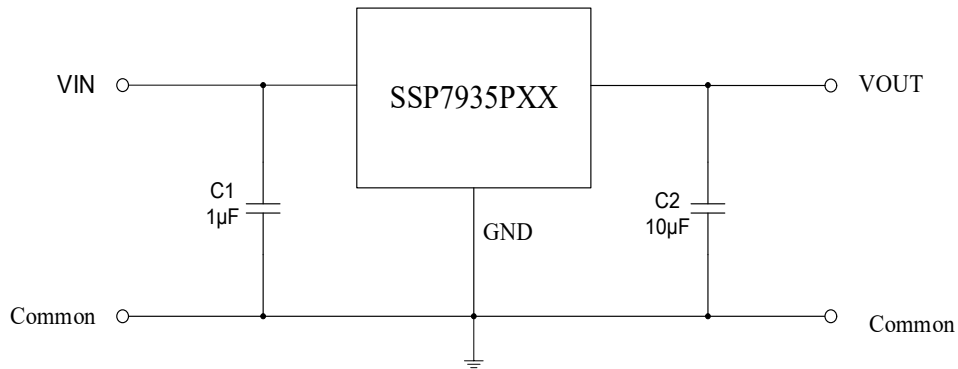

Package Information

3-pin SOT89 Outline Dimensions

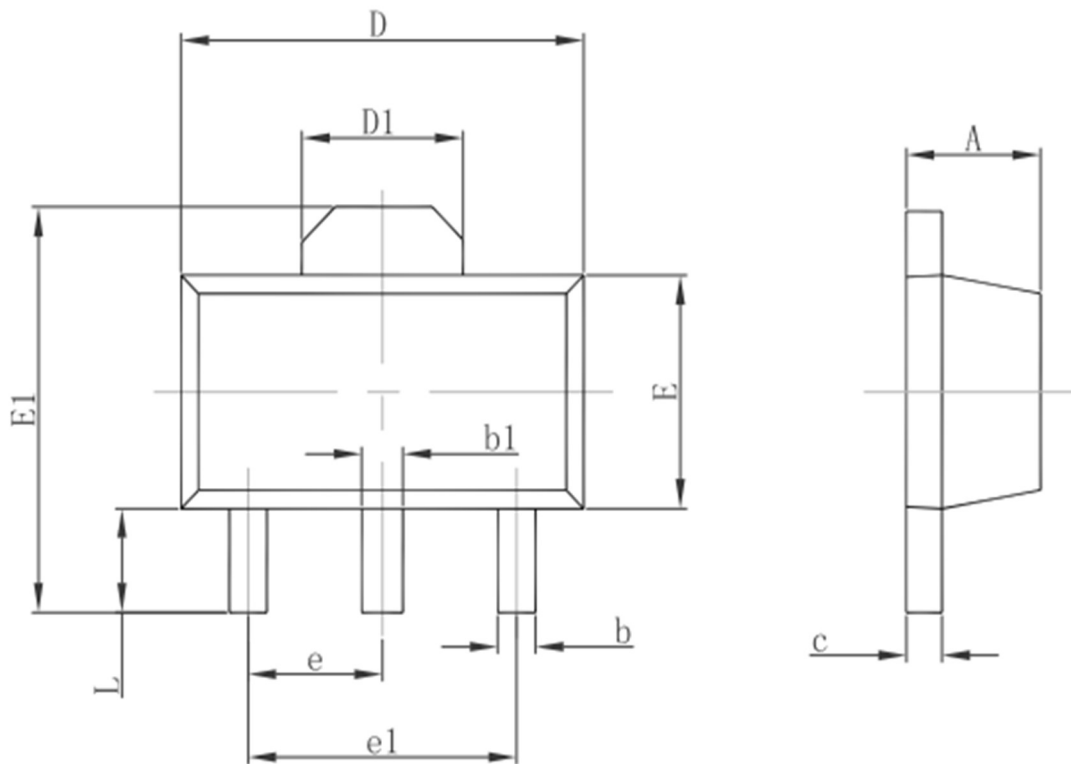

Symbol	Dimensions In Millimeters		Dimensions In Inches	
	Min	Max	Min	Max
A	1.400	1.600	0.055	0.063
b	0.320	0.520	0.013	0.020
b1	0.400	0.580	0.016	0.023
c	0.350	0.440	0.014	0.017
D	4.400	4.600	0.173	0.181
D1	1.550 REF		0.061 REF	

E	2.300	2.600	0.091	0.102
E1	3.940	4.250	0.155	0.167
e	1.500 TYP		0.060 TYP	
e1	3.000 TYP		0.118 TYP	
L	0.900	1.200	0.035	0.047

3-pin SOT23-3 Outline Dimensions

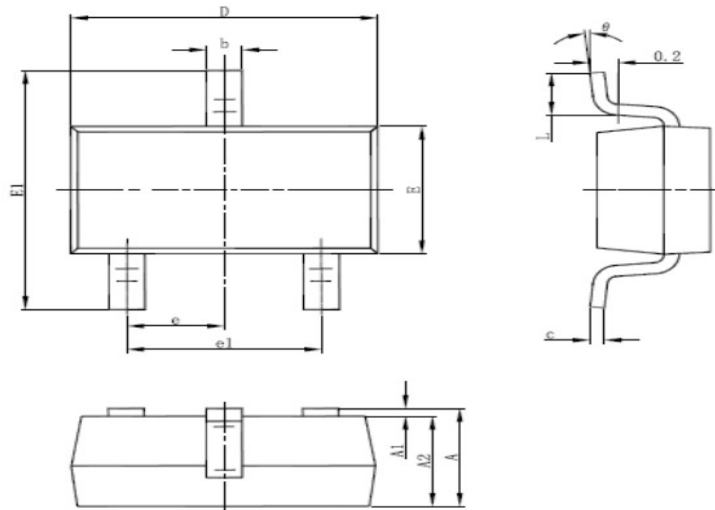

Symbol	Dimensions In Millimeters		Dimensions In Inches	
	Min	Max	Min	Max
A	1.050	1.250	0.041	0.049
A1	0.000	0.100	0.000	0.004
A2	1.050	1.150	0.041	0.045
b	0.300	0.500	0.012	0.020
c	0.100	0.200	0.004	0.008
D	2.820	3.020	0.111	0.119
E	1.500	1.700	0.059	0.067
E1	2.650	2.950	0.104	0.116
e	0.950(BSC)		0.037(BSC)	
e1	1.800	2.000	0.071	0.079
L	0.300	0.600	0.012	0.024
θ	0°	8°	0°	8°

SOT23-5 Outline Dimensions

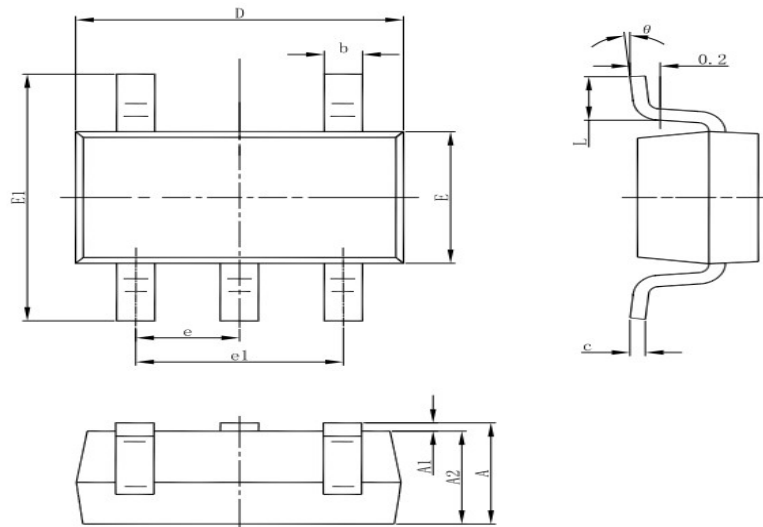

Symbol	Dimensions In Millimeters		Dimensions In Inches	
	Min	Max	Min	Max
A	1.050	1.250	0.041	0.049
A1	0.000	0.100	0.000	0.004
A2	1.050	1.150	0.041	0.045
b	0.300	0.500	0.012	0.020
c	0.100	0.200	0.004	0.008
D	2.820	3.020	0.111	0.119
E	1.500	1.700	0.059	0.067
E1	2.650	2.950	0.104	0.116
e	0.950(BSC)		0.037(BSC)	
e1	1.800	2.000	0.071	0.079
L	0.300	0.600	0.012	0.024
θ	0°	8°	0°	8°

Special Version

The company reserves the right of final interpretation of this specification.

Version Change Description

Versions: V1.2

Writer: Si Yuan Wu

Time: 2021.10.29